

# MANUAL

## CONTROL UNIT FOR ROTATING HEAT EXCHANGERS

### MicroMax180



2003-09-09  
Version 1.1  
F21018901GB

## Manufacturer's declaration

The manufacturer's assurance of the agreement of the product with the demands in

THE EMC DIRECTIVE 89/336EEG including additional directives 92/31 EEG and 93/68/EEG

<b>Manufacturer</b>	IBC automatic in Höganäs Ltd Brännerigatan 5, 263 37 Höganäs, Sweden
<b>Product</b>	Control unit for rotating heat exchangers (frequency converter)
<b>Type designation</b>	MicroMax180
<b>EC directives applied to the product</b>	EN50081-1, edition 1, 1992 EN50081-2, edition 1, 1993 EN50082-1, edition 1, 1992 EN50082-2, edition 1, 1995

The manufacturer assures on his own responsibility that the product which this assurance concerns corresponds with the demands in the EC directives stated above.

Höganäs 2003-09-09

IBC automatic i Höganäs ab

Christer Persson  
MD

---

To fulfill the EMC directive, a screened cable must be used for the engine and control signals.

The screen must be connected at both ends.

Connection instruction:  
**MicroMax180**

**IBC** automatic



CE

### Page reference

Functional description	2
Other operational functions	
General data	
Connection diagram	3
Connections	
Manual driving (at test)	
Check before switching on the control unit	4
Putting the equipment into operation	
Operation indications	5
Alarm indications	

## Functional description

- MicroMax180 – enclosed IP54, is a modern frequency converter with the additional functions which are necessary to control a rotating heat exchanger optimally. Input signal 0-10 V.
- The number of revolutions of the heat exchanger and in consequence its efficiency is regulated by the control unit so that the number of revolutions of the rotor is proportional to the input signal from the control central.

## Other operational functions

**Purification** The heat exchanger rotates at minimum speed for 10 seconds every 30 minutes if the input signal is below the threshold value, that is the rotor does not move. The function can be disconnected via a DIP change-over switch.

**Rotation monitor** The rotation monitor (a magnet installed on the rotor with the magnetic transducer belonging to it) stops the converter and sounds the alarm at belt breaking or the like. The control unit is released if a pulse is not received every 5 minutes. The function can be disconnected via a DIP change-over switch.

**Threshold value** The control unit has a preset threshold value of 0.1 V. If the input signal is below this value, the rotor stops.

**Resetting** Via a reset button alternatively a voltage drop.

**Restart** Automatic restart after a voltage drop.

**Separation** Separation between engine and control ought not to take place when loaded.

## General data

<i>Engine performance max.</i>	180	W	<i>Acceleration time</i>	(Fixed) 30	s
<i>Engine current max.</i>	1,4	A	<i>Retardation time</i>	(Fixed) 30	s
<i>Overload 2 min/30min</i>	2,1	A	<i>Ambient temp.</i>		
<i>Connection voltage</i>	1x230, +6-10%	V	<i>not condensing</i>	0-45	°C
<i>Connection frequency</i>	50-60	Hz	<i>Protection form</i>	IP54	
<i>Output voltage</i>	3x0-230	V	<i>Weight</i>	0,9	kg
<i>Output frequency</i>	4-100	Hz	<i>Measures, hxbxd</i>	158x164x60	mm
<i>Min. frequency</i>	(Fixed) 4	Hz	<i>Internal fuse</i>	2,5	AT
<i>Max. frequency</i>	40-100	Hz	<i>Incoming fuse max.</i>	10	A

## Connection diagram

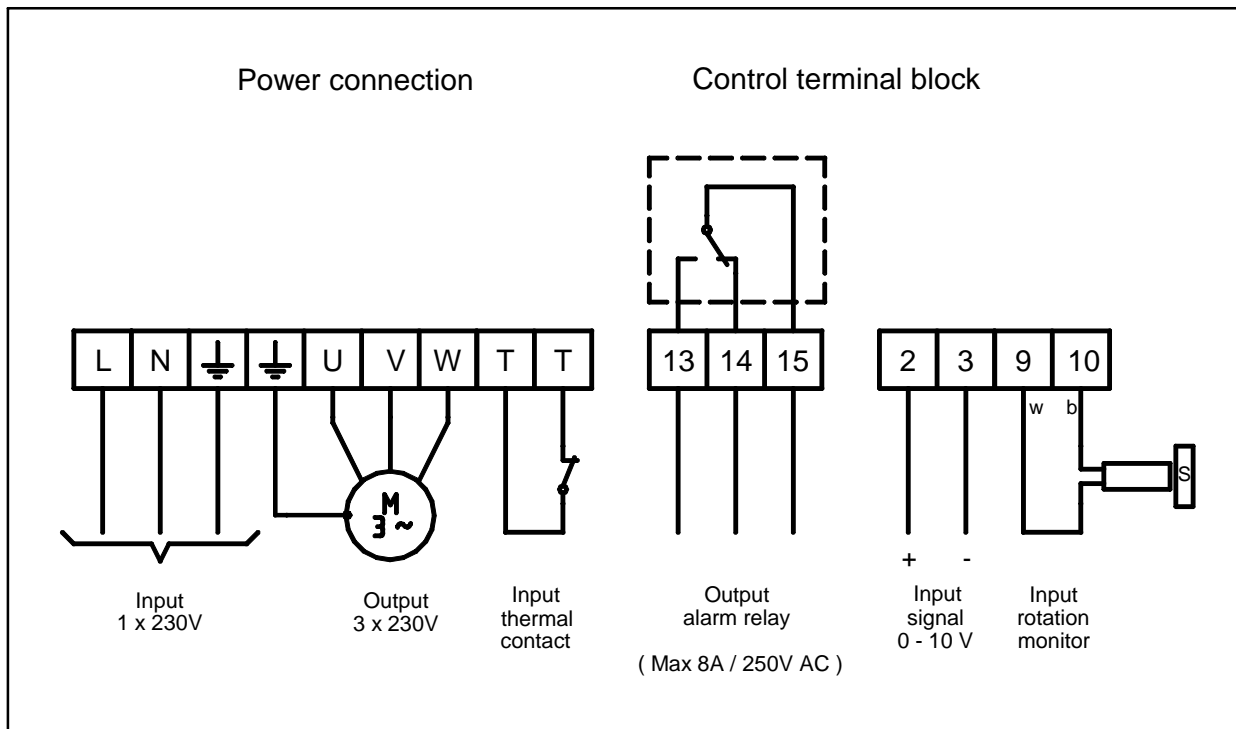

## Connections

### **Thermojunction (T-T)**

Must be looped if the thermojunction of the engine is not connected.

### **Alarm relay (13-14-15)**

Closes between 14 - 15 at alarm or voltage drop.  
Max 8A/250V AC.

### **Input signal (2-3)**

0-10V

### **Rotation monitor (9-10)**

White cable is connected to terminal block 9, brown cable to terminal block 10. The magnet is installed with the south side towards the transducer. Max. distance 15 mm.

## Manual driving (at test)

### **At high-speed**

The engine rotates at preset max. revolutions, when the DIP switch is in the position On.

### **At low-speed**

The engine rotates at preset min. revolutions, when the DIP switch is in the position On.

## Check before switching on the control unit

- Check that** the engine has been connected for 3 x 230 V. If a circuit breaker has been connected between the engine and the control unit, the thermojunction of the engine should be connected through an auxiliary contact in the circuit breaker.
- Check that** the control unit has been connected according to the instruction on page 3. Feeding tension 230V + 6 - 10 %.
- Check that** the rotation monitor and the purification function have been connected.

## Putting the equipment into operation

### Should be done in the right order

- Check that** the engine rotates in the right direction compared with the rotation direction of the rotor. If there is an error two phases are changed over to the engine.
- Adjustment of max. rpm** Put the DIP change-over switch for "High-speed" in the position On alt. use 0 - 10 V input signal. Adjust "Max. rpm" so that the rotor rotates at 10 -12 rpm (or according to the instruction of the rotor manufacturer).
- Check of min. rpm** Put the DIP change-over switch for "Low-speed" in the position On. Check that the rotor starts. The min. rpm is permanently adjusted.
- Check of rotation monitor** Put the DIP change-over switch for "High-speed" in the position On. The indication "Rotation" (yellow light diode 2) flashes when the magnet passes the magnetic transducer. This whether the DIP change-over switch for "Rotation monitor" is in the position On or Off.
- Purification** It is tested when the tension is switched on. If the DIP change-over switch for the purification function is on and the input signal is lower than the threshold value (0.1 V) the rotor starts the purification directly when the tension is switched on.
- Finish by** letting the control central run the rotor at max. and min. rpm and checking that the speed of the rotor is right.

## Operation indications

<b>On (green)</b>	"Tension on" gives a fixed light. Flashes when the control unit has been released.
<b>Operation (yellow 1)</b>	Is lighted when operation is allowed, i.e. when the input signal exceeds the threshold value.
<b>Rotation (yellow 2)</b>	Flashes when the rotation monitor is influenced, irrespective of the adjustment of the DIP change-over switch.

## Alarm indications

**The green light diode flashes and the red light diode below is lighted.  
All alarms remain.**

In the cases below the control unit must be reset.

<b>Rot. monitor (red 1)</b>	<b>The control unit has been released because of the rotation monitor.</b>
---------------------------------	--

Probable cause of failure at installation:	<ul style="list-style-type: none"><li>- The magnet has been turned the wrong way.</li><li>- The magnetic transducer has been wrongly connected (the wrong polarity). See connections page 3.</li></ul>
--	--

Probable cause of failure at operation:	<ul style="list-style-type: none"><li>- The belt has been broken.</li><li>- The belt slips.</li><li>- The rotor has got stuck.</li><li>- The magnetic transducer or the magnet is not intact.</li></ul>
---	---

<b>Engine temp. (red 2)</b>	<b>The thermojunction of the engine has been released because of a too high winding temperature.</b>
---------------------------------	--

Probable cause of failure:	<ul style="list-style-type: none"><li>- See Alt 1 Excess current on page 6.</li></ul> <p>The thermojunction of the engine goes back to its normal position when the temperature sinks.</p>
----------------------------	--

<b>Over-voltage (red 3)</b>	<b>Over-voltage.</b>
---------------------------------	----------------------

Probable cause of failure:	<ul style="list-style-type: none"><li>- The input voltage exceeds 250 V for more than 4 - 5 sec. after that the control is released.</li></ul>
----------------------------	--

<b>Under-voltage (red 4)</b>	<b>Under-voltage.</b>
----------------------------------	-----------------------

Probable cause of failure: - The input voltage is below 205 V for more than 4 - 5 sec., after that the control is released.

**Over-voltage and under-voltage**

**(red 3 and 4)**

Probable cause of failure:

**Alt 1. Excess current.**

The control unit limits the current at 2,4A and then is released after 4 -5 sec.

- The engine is too small compared with the rotor diameter.
- The rotor runs stiffly.
- The engine is out of order, for example a fault of bearing. Measure the current.

N.B. With the VVX engine 25W/75 rpm the control is not released, because, even when the engine shaft is not moving, the current is below 2,4 A. This means that after 5 - 6 min. the control is released on the rotation monitor. Possibly the control can also be released on the thermojunction if the engine gets too hot.

**Alt 2. Short-circuit phase - phase.**

The control unit limits the current at 2,4 A and then is released after 4 - 5 sec.

Probable cause of failure:

- Winding fault in the engine. Measure the engine resistance, it should be approximately the same on all phases.
- Short-circuit between the phases in the cable.

**Alt 3. Short-circuit phase - earth (earth fault).**

The control unit is released directly.

Probable cause of failure:

- Earth fault in the engine or the cable.

N.B.

To reset the control unit at an earth fault you must see to it that it is without tension.

N.B.

The right value of voltage and current can only be obtained with a moving-iron instrument.

**IBC automatic**

Brännerigatan 5 S-263 37 HÖGANÄS  
TEL 042-33 00 10 FAX 042-33 03 75