

Assembly instruction

for Enventus sectorized rotor

Components:

- Rotorsegments
- Hub with shaft, bearings and coverplates
- Radial walls
- Periphery plates with plate- and locking nuts
- Bolts with nuts for periphery plates

Accessories:

- Lifting tackle
- Safety strap (minimum 300kg)
- Tools
 - Box spanners
 - Hammer, rubber hammer
 - Screw drivers
 - Etc.

Enventus AB

Hedenstorpsvägen 4 – SE-555 93 Jönköping – Sweden
E-Mail: info@enventus.com – www.enventus.com
Tel. +46 36 37 56 60 – Fax +46 36 37 56 68

Enventus GmbH

Jägerstrasse 2 – CH-8406 Winterthur – Switzerland
E-Mail: info@enventus.com – www.enventus.com
Tel. +41 52 202 00 44 – Fax +41 52 202 00 88

Rotor assembly

Alignment of the hub

Screw a radial wall to the hub and mount the hub in the casing with centerbolts without fixing it permanently.

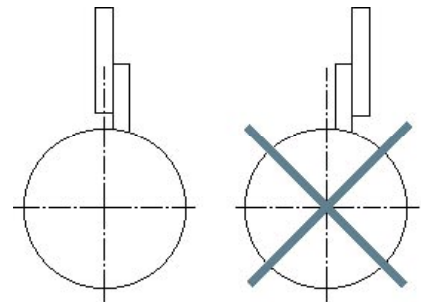
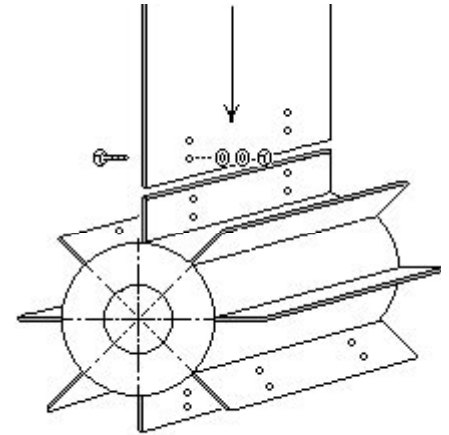

Alignment of the radial walls to the axis

The radial wall must be square with the axis (90°). Check this meditation of the clearances between radial wall and the casing framework. Clearances a-a and b-b must be equal.

If necessary, realign the radial wall, then screw it down.

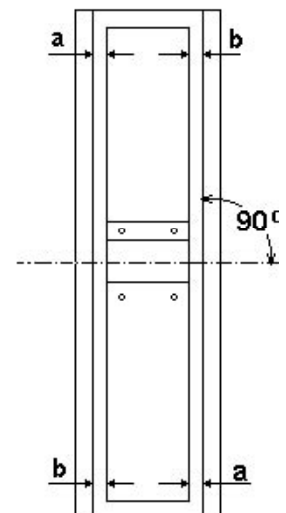

Screw the opposite radial wall to the hub.
Align the hub with radial wall to the casing.

Alignment of the radial wall with hub to
the housing.

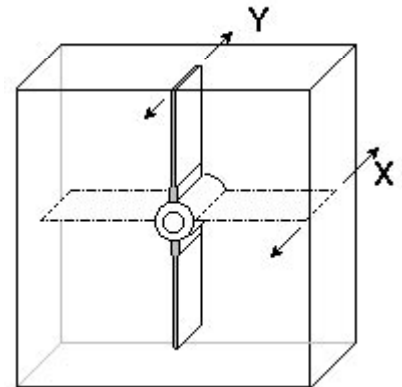

Alignment of the rotor in direction X

Clearances a-b and b-a must be equal. If not, loosen the bearing block bolts (on both sides) and correct the clearances. Displace the unit hubradial wall-bearing blocks in axial direction.

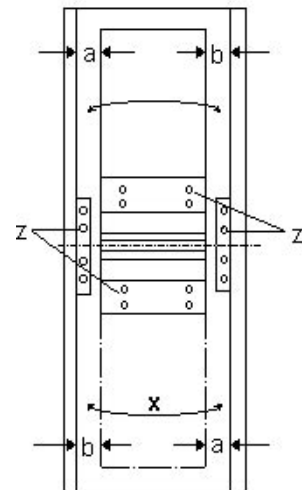

Alignment of the rotor in direction Y

Clearances c-d must be equal. If not, loosen the bearing block bolts (on the respective side), lift the bearing block and correct the alignment.

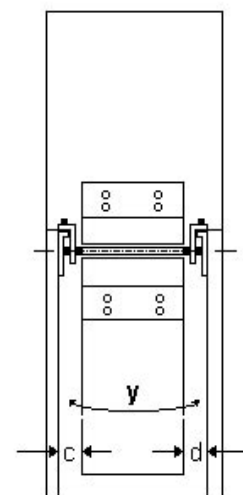

Alignment of the remaining radial walls

Align the remaining radial walls one after the other. It must be strictly observed that their clearances to the casing framework are the same as the clearance between casing framework and first radial wall.

WARNING
RISK OF AN ACCIDENT

Prior to installation of the rotor segments, the rotor must be blocked ! (for example with square timber).

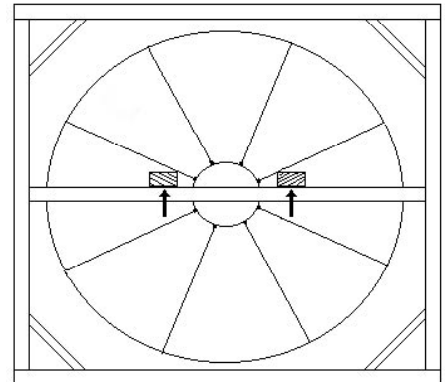

Assembly of the rotorsegment and the periphery plate

Mount the first rotorsegment. Note the marking on the segments, it is important that the segments are assembled in correct order.

The segments are marked on the periphery with, in the middle, the number of the specific segment and on each side of the periphery, the number of the segments which shall be mounted next to each side of this specific segment.

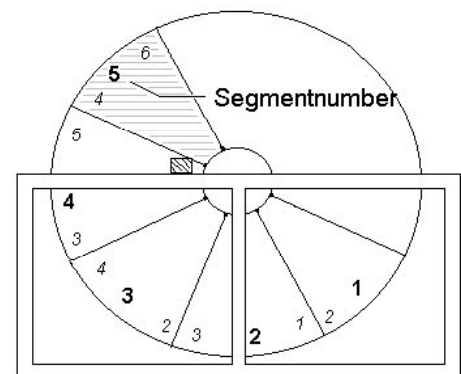

Mount a periphery plate over the segment and fix it to radial wall no 1 with plate and nut. Do not fix the periphery plate to the radial wall on which the next rotor segment is being mounted (radial wall no 2).



Mount rotorsegment no 2 as well as periphery plate no 2 according to the first assembly.

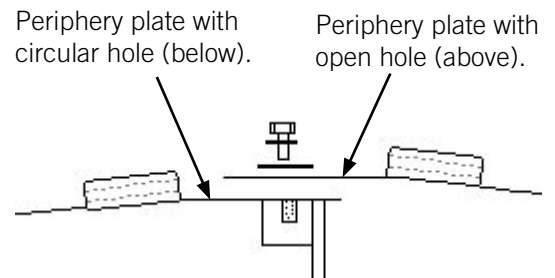

Fix upper part of periphery plate no 1 and lower part of periphery plate no 2 to radial wall no 2 with plate and nut. Do not fit the nuts finally since adjustments will be necessary later on. Mount the long M10 bolts between the two periphery plates without fixing it finally.

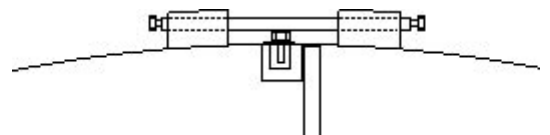

Since the rotor is not balanced, it must be secured by a lifting tackle before the square timbers can be removed !

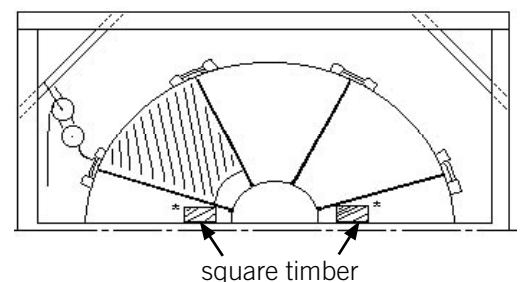

Assemble the rest of the segments and the periphery plates accordingly. Adjust the rotor segments sidewise so that the rotor surface is flat.

Clamping of the rotor

Tighten uniformly the loosely screwed-in rotor clamping bolts. According to the order of segment installation, the bolts are tightened cross-wisely on the opposite segments.

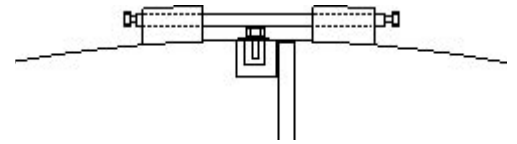

The rotor is properly mounted and clamped when all segment flanks sit close.

Finally, the loosely screwed fastening bolts (with washers and spring washers) must be tightened.

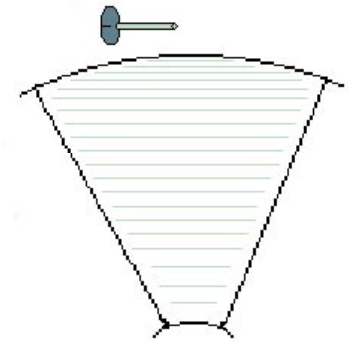

Hub covering

Mount the coverplates over the hub.

